

H735, HX38, HX48, HX58 SERIES

Status and Control in One Package



The Hawkeye Relay Combination Series is the ideal solution for the automation installer. These units combine a current switch and relay into a single package, reducing the space required for total control of fans and pumps. The current switch and relay operate independently of one another. These devices allow start/stop control and status monitoring with one device instead of two.

SPECIFICATIONS

Sensor Power	Induced from monitored conductor
Insulation Class	600 Vac RMS
Frequency Range	50/60 Hz
Temperature Range	-15 to 60 °C (5 to 140 °F)
Humidity Range	10 to 90% RH non-condensing
Hysteresis	10% Typical
Terminal Block Wire Size	24 to 14 AWG (0.2 to 2.1 mm ²)
Terminal Block Torque	3.5 to 4.4 in-lbs (0.4 to 0.5 N-m)

WARRANTY

Limited Warranty	5 years
------------------	---------

AGENCY APPROVALS

Agency Approvals	UL 508 open device listing, CAT III, Pollution Degree 2, basic insulation
------------------	---



Note: Do not use the LED status indicators as evidence of applied voltage.

Combined relay & status

Combines command relay and fan/pump status sensor in a single, easy-to-install unit

Fan & pump status

Detect belt loss and motor failure...ideal for fan and pump status

Polarity insensitive

Polarity insensitive status outputs...fast and easy installation

APPLICATIONS

- Starting/stopping and monitoring positive status of motors
- Detecting belt loss and coupling shear

Two outputs

H748 and H948 feature a SPDT command relay...control two outputs with a single relay

Added flexibility

Bracket on H938, H948, and H958 can be installed in three different configurations

Easy setup

Relay and status LEDs

DETECTS BELT LOSS/COUPLING SHEAR!

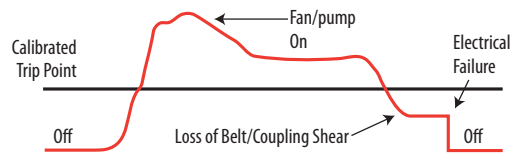

Now you can easily detect when drive belts slip, break, or pump couplings shear. In fact, a typical HVAC motor that loses its load has a reduction of current draw of up to 50%. That's why our sensors are the industry standard for status.

RELAY CONTACT RATINGS

H735 (SPST, N.O.)		
Resistive	5 A @ 250 Vac, 30 Vdc	
Inductive	3 A @ 250 Vac, 30 Vdc	
Hx38, Hx58 (SPDT N.O.)		
Resistive	10 A @ 250 Vac, 30 Vdc	
Inductive	5 A @ 250 Vac, 30 Vdc	
Hx48 (SPDT)		
Resistive	8 A @ 250 Vac, 30 Vdc	
Inductive	3.5 A @ 250 Vac, 30 Vdc	

TYPICAL COIL PERFORMANCE

Voltage	AC	DC
24V	10 mA	10 mA
12V (Hx58)		20 mA
Pull-in Voltage		
Hx3x		20.1 Vdc
Hx48		20.1 Vdc
Hx58		8.4 Vdc
Drop-out Voltage		
Hx3x		5.2 Vdc
Hx48		5.2 Vdc
Hx58		3.0 Vdc

H735/738/748/758

Dimensional Drawing

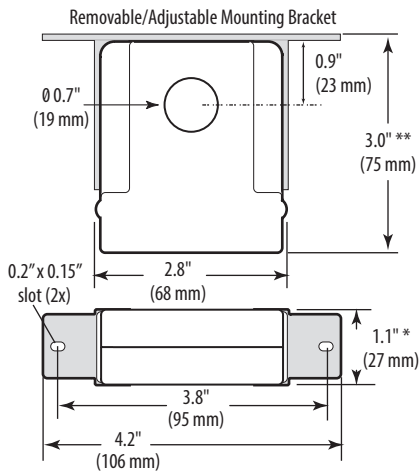

* Terminal block may extend up to 1/8" over the height dimensions shown.
 ** Slide switch may extend up to 1/4" over the height dimensions shown.

START/STOP MONITORING OF FAN /PUMP MOTORS

Wiring Diagram

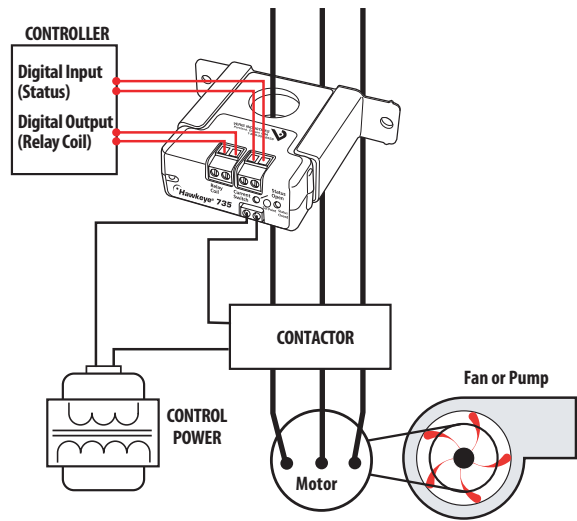

H938/948/958

Dimensional Drawing

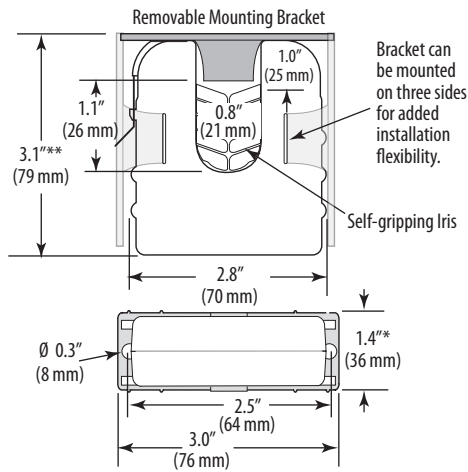

* Terminal block may extend up to 1/8" over the height dimensions shown.
 ** Slide switch may extend up to 1/4" over the height dimensions shown.

RELAY CONTROLLED DIRECTLY BY STATUS CONTACTS

Wiring Diagram

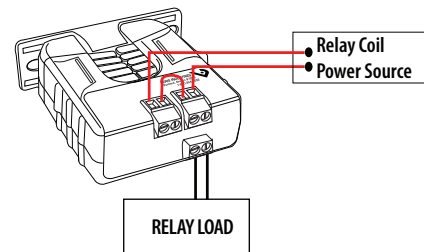

ORDERING INFORMATION

MODEL	AMPERAGE RANGE	STATUS OUTPUT (MAX.)	MIN. TRIP POINT	RELAY	COIL VOLTAGE	HOUSING	STATUS LED	RELAY POWER LED	UL
H735	1 to 135 A	0.1 A @ 30 Vac/dc	1 A or less	SPST, N.O.	24 Vac/dc	Solid-core	•	•	•
H738	1 to 135 A	1.0 A @ 30 Vac/dc	1 A or less	SPST, N.O.	24 Vac/dc	Solid-core	•	•	•
H748	1 to 135 A		1 A or less	SPDT	24 Vac/dc	Solid-core	•	•	•
H758	1 to 135 A		1 A or less	SPST, N.O.	12 Vdc nom.	Solid-core	•	•	•
H938	2.5 to 135 A		2.5 A or less	SPST, N.O.	24 Vac/dc	Split-core	•	•	•
H948	2.5 to 135 A		2.5 A or less	SPDT	24 Vac/dc	Split-core	•	•	•
H958	2.5 to 135 A		2.5 A or less	SPST, N.O.	12 Vdc nom.	Split-core	•	•	•
				SPST, N.O.	12 Vdc nom.	Split-core	•	•	•

